

### X20-7.4-M-830-\* HLS Technical Specification

### X20-12-M-830-\* HLS

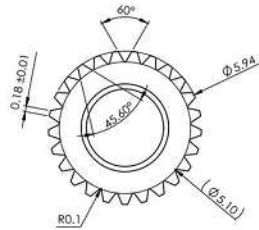

25T 6mm Output Shaft Spline

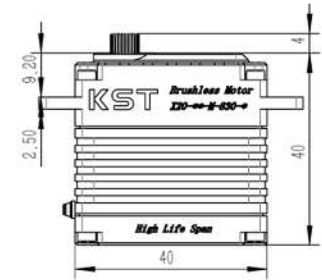
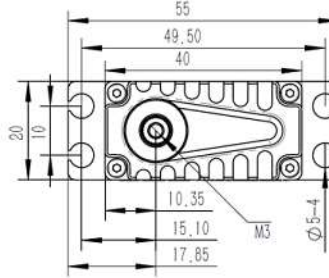

## 1. Operating Data

	X20-7.4-M-830-*	X20-12-M-830-*
Rated Voltage	DC7.4V	DC12.0V
Voltage Range	DC6.0V-8.4V	DC9.0V-13V
Stalling Torque	3.8N.m@7.4V	4.5N.m@12V
Rated Torque	0.9N.m@7.4V	1.1N.m@12V
Stalling Current	4.95A	3.25A
Rated Current	1.25A	0.85A
No-load Speed	0.13sec/60°@7.4V	0.13sec/60°@12V
Rated Speed	0.22sec/60°@7.4V	0.23sec/60°@12V
Working Frequency	1520us/333Hz	
Default Travel Angle	± 100°=200°Total When 500us-2500us	
Temperature Range	-10°C.....+65°C	
Case Material	Aluminum Alloy	
Motor Type	Brushless DC Motor	
Gear Set Material	Hardened Steel	
Position Sensor	Contactless	
Case Dimensions	40mm*20mm*40mm±0.2mm	
Weight	80g±10%	
Ball Bearing	6 BB	

## 2. Performance

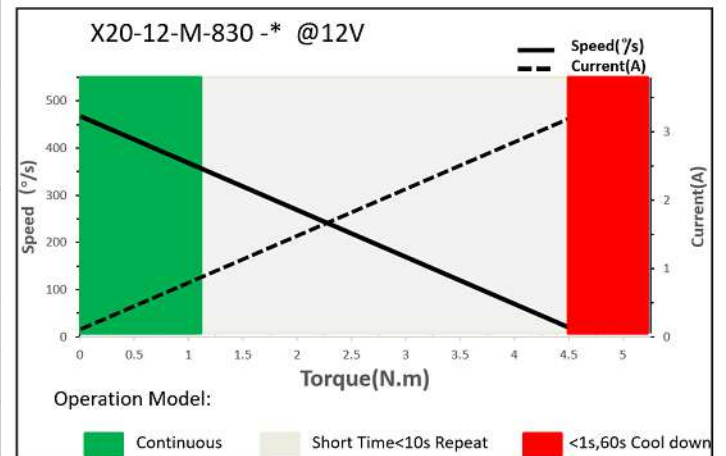
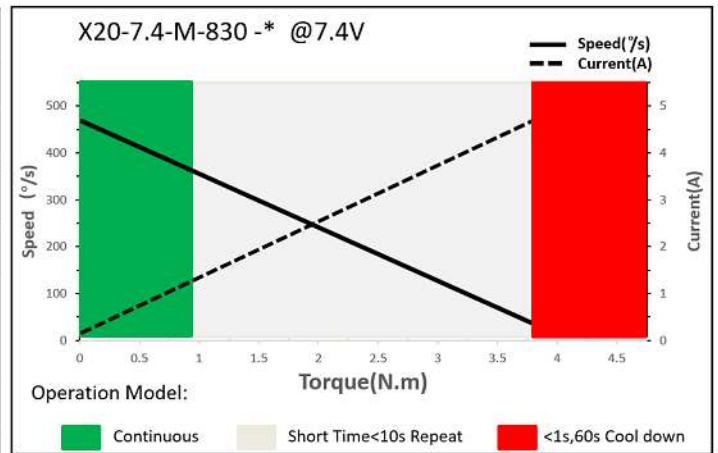

## 3. Command signal

### 3.1. PWM Command Interface

Signal Voltage	TTL-level: HIGH: min.3.3V, max.5.0V Low: min.0.0V, max.1.5V
Pulse Lengths	500us-2500us
Pulse Lengths for Position-100°/0°/+100°	500us/1500us/2500us

### 3.2. RS485 Command Interface

Baud-Rate	115200 ±1.5% bits/s
Protocol (Documentation available)	10 Byte (incl. 1 byte Check Sum)

#### 3.2.1. RS485 Protocol Specifications

Number of Data Bits	8
Number of Stop Bits	1
Parity	None

#### 3.2.2. Command / Response Frame

Byte #	Description	Byte #	Description
1	Frame Head(0xFE)	6	Data
2	Version(0xCA)	7	Data
3	Address	8	Data
4	Command code	9	Check Sum
5	Data	10	(0A) Frame End

### 3.3. CAN Bus Command Interface

Baud-Rate	500Kbps
Node number	0 x25 (range 1 ~ 127, 0 is radio)
Communication	3.1: CAN Open standard frame format 3.2: CANOPEN Extended frame

### 3.4. Feedback Singnal

#### 3.4.1. Position Feedback Signal (PWM Versions)

The Position Feedback signal is an output signal with a square wave which is directly related to the output shaft's angular position. Reference is Supply Ground.

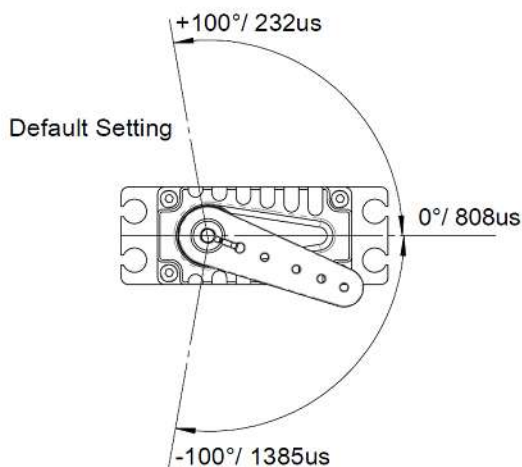

Position Feedback

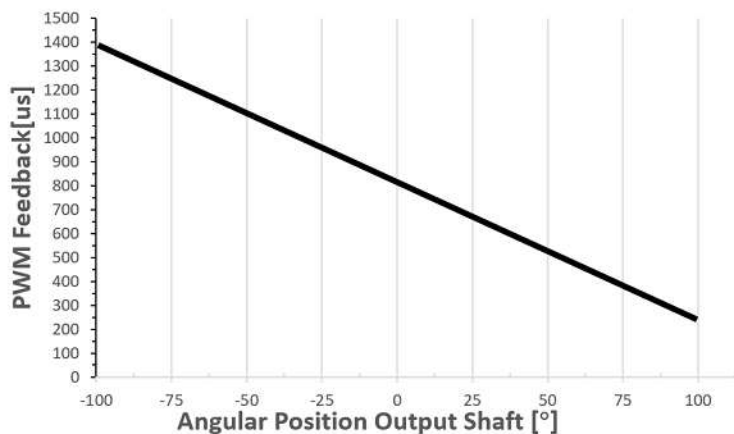

\* Tolerance ±1%

**4.4.2 Feedback Value (Bus Versions)**

Integrated in the Bus protocol a Feedback Value, including the Angle position, Temperature, current value. Value read by sending request command. Provide the details of the bus in the document.

**4. Electrical Connection Options**

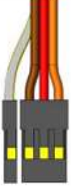
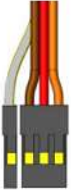
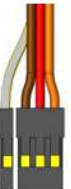
 4 3 2 1	<b>Pin Assignment (PWM)</b>			
	1	Yellow	SIG	Command Signal
	2	Red	DC+	Supply Voltage
	3	Brown	DC-(GND)	Supply Ground, Signal Ground
	4	White(Options)	Feedback	Position Feedback
 4 3 2 1	<b>Pin Assignment (RS485)</b>			
	1	Yellow	RS485A	Non-Inverted Input / Output line
	2	Red	DC+	Supply Voltage
	3	Brown	DC-(GND)	Supply Ground, Signal Ground
	4	white	RS485B	Inverted Input / Output line
 4 3 2 1	<b>Pin Assignment (CAN_BUS)</b>			
	1	Yellow	CAN_H	CAN high
	2	Red	DC+	Supply Voltage
	3	Brown	DC-(GND)	Supply Ground, Signal Ground
	4	white	CAN_L	CAN low

**5. Accessories (Options)**

Item	Item-No.
Aluminum Servo Arm (Single side )	<b>0625.11</b>
Aluminum Servo Arm (Single side)	<b>0625.23</b>
Aluminum Servo Arm (Single side )	<b>0625.40</b>
Aluminum Servo Arm (Double side)	<b>0625.60</b>

**6. Item Number System**

