

FH2-HY04

H₂ DETECTOR **FH2-HY04** for HYDROGEN LEAK DETECTION

The FH2-HY04 is a newly developed hydrogen detector, specifically designed for preventing hydrogen leaks in fuel-cell vehicles (FCV). For this application, a reliable hydrogen sensors is required and FIS has developed a new catalytic combustion type hydrogen sensor with a minimum mass and wide surface area using a unique technology.

The development of this sensor realizes a rapid response speed and strong poisoning resistance against silicone compounds. These features achieve the expected demands for long life in actual applications in automobiles, without any need for replacing detectors over a long period. In combination with sophisticated electronics and software design, FIS offers the following features in hydrogen leak detection.

- **Rapid response speed**
- **High accuracy**
- **Wide operating/storage temperature range**
- **Compact and light weight**
- **Long life**

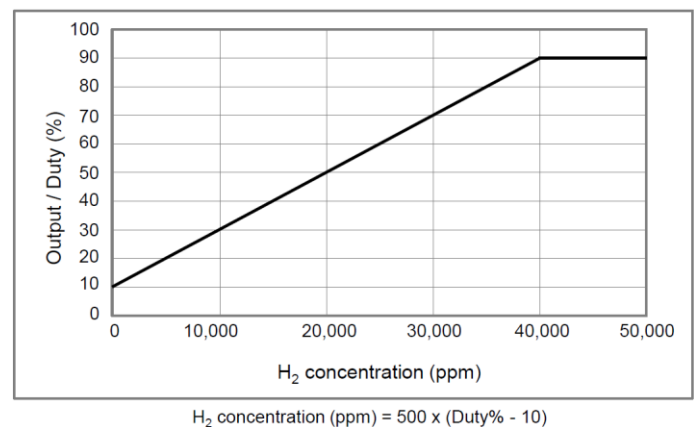
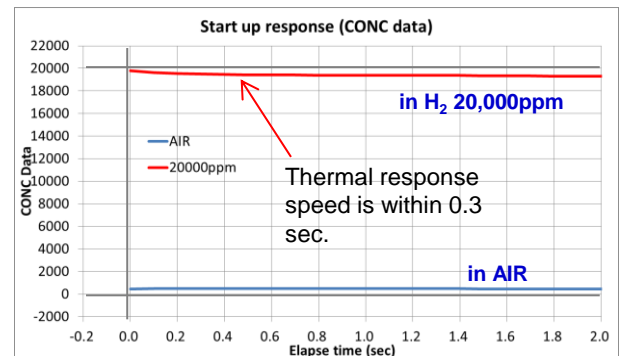

This figure is for PWM output .

SPECIFICATIONS

Model	FH2-HY04	
SPECIFICATIONS-1 Sensing performance	Detection gas	Hydrogen
	Concentration range	0 ~ 4 vol.% in air
	Initial accuracy	± 10%
	Speed of response (T80)	< 2 seconds
	Start-up time	< 1 second
SPECIFICATION-2 Electrical	Supply voltage	12V (9 ~ 16 V) DC
	Power consumption	Approx. 1.0W
	Output signal	PWM (10 ~ 90% duty) CAN Note1
SPECIFICATION-3 Environmental	Operating temperature range	-35°C ~ 85°C
	Storage temperature range	-40°C ~ 105°C
	Humidity	< 95%RH (no condensation)
SPECIFICATION-4 Mechanical	Dimensions (without the attaching part)	62 (W) × 49 (D) × 22.5 (H) mm
	Weight	Approx. 58g

Note 1:CAN specifications will be customized.
Please contact us

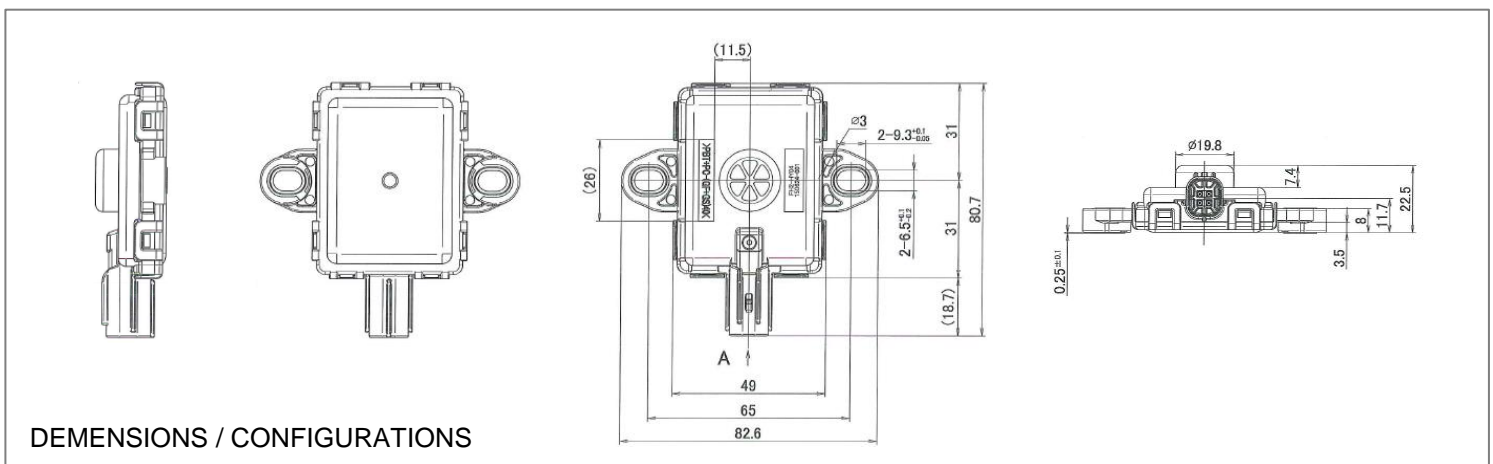

Please contact

May, 2017

FIS Inc.

3-36-3 Kitazono, Itami, Hyogo
664-0891 JAPAN
Tel: +81-72-780-1800
Fax: +81-72-785-0073
<http://www.fisinc.co.jp>